

HOFFER

Perfecting Measurement™



Предусилитель сигнала серии Pet

Технические характеристики

Архангельск (8182)63-90-72
Астана +7(7172)727-132
Белгород (4722)40-23-64
Брянск (4832)59-03-52
Владивосток (423)249-28-31
Волгоград (844)278-03-48
Вологда (8172)26-41-59
Воронеж (473)204-51-73
Екатеринбург (343)384-55-89
Иваново (4932)77-34-06
Ижевск (3412)26-03-58
Казань (843)206-01-48

Калининград (4012)72-03-81
Калуга (4842)92-23-67
Кемерово (3842)65-04-62
Киров (8332)68-02-04
Краснодар (861)203-40-90
Красноярск (391)204-63-61
Курск (4712)77-13-04
Липецк (4742)52-20-81
Магнитогорск (3519)55-03-13
Москва (495)268-04-70
Мурманск (8152)59-64-93
Набережные Челны (8552)20-53-41

Нижний Новгород (831)429-08-12
Новокузнецк (3843)20-46-81
Новосибирск (383)227-86-73
Орел (4862)44-53-42
Оренбург (3532)37-68-04
Пенза (8412)22-31-16
Пермь (342)205-81-47
Ростов-на-Дону (863)308-18-15
Рязань (4912)46-61-64
Самара (846)206-03-16
Санкт-Петербург (812)309-46-40
Саратов (845)249-38-78

Смоленск (4812)29-41-54
Сочи (862)225-72-31
Ставрополь (8652)20-65-13
Тверь (4822)63-31-35
Томск (3822)98-41-53
Тула (4872)74-02-29
Тюмень (3452)66-21-18
Ульяновск (8422)24-23-59
Уфа (347)229-48-12
Челябинск (351)202-03-61
Череповец (8202)49-02-64
Ярославль (4852)69-52-93

Единый адрес для всех регионов: hrf@nt-rt.ru || www.hoffer.nt-rt.ru

TURBINE FLOWMETERS BY HOFFER

Perfecting Measurement™



PET SERIES

Preamp Signal Conditioner Mag Type
(for use with Lo-Co and TriFlo Series)

Product Bulletin PET-PSC-100A

TECHNICAL DATA SHEET

PRODUCT DESCRIPTION

The PET Series mag-preamps are designed to convert low level sinusoidal signals into stable square wave pulses. The signal conditioners are built to fit a compact "ELBY" type explosion-proof enclosure. This PET is designed for use with the Lo-Co Series and TriFlo Series flowmeters.

SPECIFICATIONS

Supply Voltage: 7.5 – 30 VDC regulated.
12 – 30 VDC regulated. (PET-5)

Supply Current @ 30 VDC max:
≤ 3 mA (0-5 V).
≤ 12mA (0-10 V).
≤ 20mA (OC).
≤ 5mA (Current Loop).

Output Signal: Std.: 0-10 V.
R Load > 20 kΩ TTL: 0-5 V.
OC: Open Collector, NPN.

Frequency Range: 5Hz to 10kHz at specified sensitivity.

MODEL NUMBERS

PET-4 TTL/CMOS (0-5 VDC)
PET-5 0-10 VDC Square Pulse.
PET-6 Open Collector.

Input Sensitivity: 30 mVpp.
Distance Pickoff/Preamp: 500 ft. max.
Temperature Range: -40° to +221°F
(-40° to +105°C).
Terminal/Pin Connections: 1. Input VDC. 4. Mag Pickup.
2. Common. 5. Mag Pickup.
3. Pulse Out (+).
CE-Compliance: EN55011, EN500222.

DIMENSIONAL INFORMATION

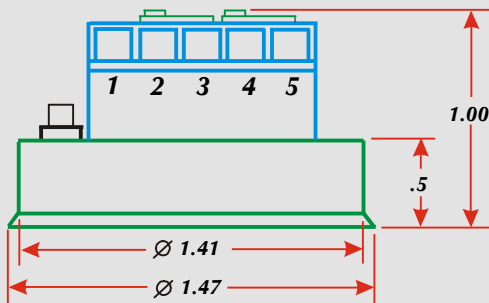

General Purpose

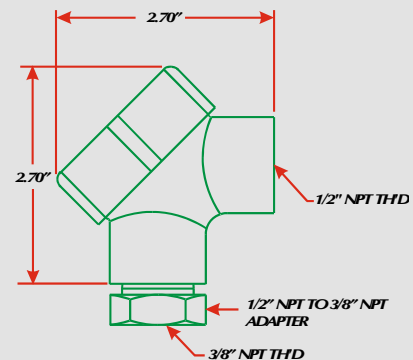

Explosion-Proof

ORDERING INFORMATION

PET- (A) - (B) - (C) - CE

OUTPUT

- 4 TTL/CMOS (0-5 VDC).
- 5 0-10 VDC Square Pulse.
- 6 Open Collector.

ENCLOSURE

- 1 General Purpose.
- 2 ELBY Type Explosion Proof Enclosure.
CLASS I DIV 1 & 2, GROUPS C & D
CLASS II, DIV 1 & 2 GROUPS E, F & G
CLASS III
UL & CSA LISTED
(Not for use in ATEX or IEC classed areas. Single 1/2" FNPT conduit connection.)

OPTIONS

- (X) None.
- (1) 1/2" MNPT x 1" FNPT adapter for use with ELBY Enclosure to Mount to Standard 1" Flowmeter Riser.

TYPICAL INSTALLATION WIRING

Model PET-4
TTL/CMOS (0-5 VDC)

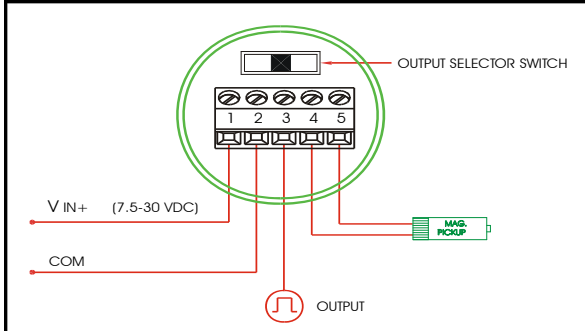

Model PET-5
0-10 VDC Square Pulse

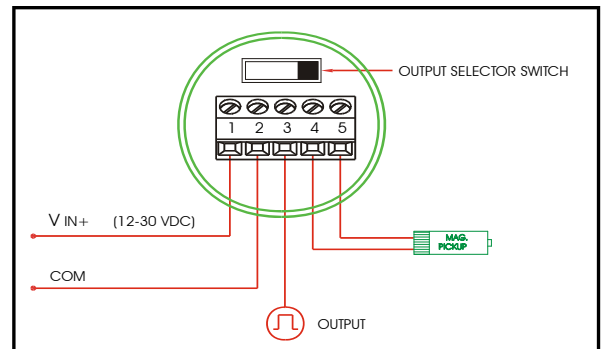

Model PET-6
Open Collector

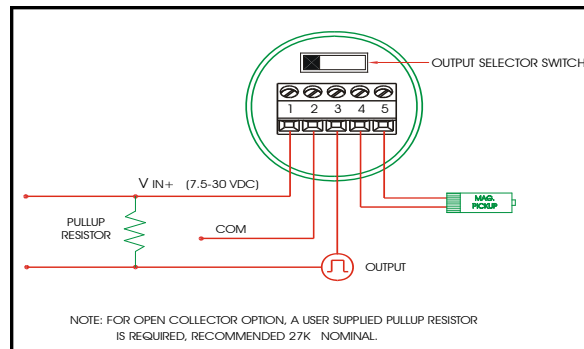

По вопросам продажи и поддержки обращайтесь:

Архангельск (8182)63-90-72
Астана +7(7172)727-132
Белгород (4722)40-23-64
Брянск (4832)59-03-52
Владивосток (423)249-28-31
Волгоград (844)278-03-48
Вологда (8172)26-41-59
Воронеж (473)204-51-73
Екатеринбург (343)384-55-89
Иваново (4932)77-34-06
Ижевск (3412)26-03-58
Казань (843)206-01-48

Калининград (4012)72-03-81
Калуга (4842)92-23-67
Кемерово (3842)65-04-62
Киров (8332)68-02-04
Краснодар (861)203-40-90
Красноярск (391)204-63-61
Курск (4712)77-13-04
Липецк (4742)52-20-81
Магнитогорск (3519)55-03-13
Москва (495)268-04-70
Мурманск (8152)59-64-93
Набережные Челны (8552)20-53-41

Нижний Новгород (831)429-08-12
Новокузнецк (3843)20-46-81
Новосибирск (383)227-86-73
Орел (4862)44-53-42
Оренбург (3532)37-68-04
Пенза (8412)22-31-16
Пермь (342)205-81-47
Ростов-на-Дону (863)308-18-15
Рязань (4912)46-61-64
Самара (846)206-03-16
Санкт-Петербург (812)309-46-40
Саратов (845)249-38-78

Смоленск (4812)29-41-54
Сочи (862)225-72-31
Ставрополь (8652)20-65-13
Тверь (4822)63-31-35
Томск (3822)98-41-53
Тула (4872)74-02-29
Тюмень (3452)66-21-18
Ульяновск (8422)24-23-59
Уфа (347)229-48-12
Челябинск (351)202-03-61
Череповец (8202)49-02-64
Ярославль (4852)69-52-93

Единый адрес для всех регионов: hfr@nt-rt.ru || www.hoffer.nt-rt.ru



The specifications contained herein are subject to change without notice and any user of said specifications should verify from the manufacturer that the specifications are currently in effect. Otherwise, the manufacturer assumes no responsibility for the use of specifications which may have been changed and are no longer in effect.

The quality system covering the design, manufacture and testing of our products is certified to International Standard ISO 9001.

